

# UPC

*User's manual*



## Trademark Acknowledgments

- SATIR is a trademark of SATIR Ltd.
- Other names and products not mentioned above may be registered trademarks or trademarks of their respective companies.

Copyright © 2019 SATIR Ltd. All rights reserved.

We are very grateful for using our product, please read the manual carefully before using the camera. It will provide the correct illustration for you to install and use.

Copyright statement:

SATIR Ltd. owns the copyright of this user's manual. Without approve of SATIR, any organization or individual have no right to copy and reprint any part of it.

SATIR reserves the right to change the functions and configurations of our products without prior notice.

If you have a problem, which is not mentioned in the manual during the process of using the camera, please contact us or your authorized agent.

You can visit our website [www.satir.com](http://www.satir.com) to get the latest information for more products.

# Contents

1	Reading this first.....	1
1.1	Safety precautions.....	1
1.1.1	Warning.....	1
1.1.2	Caution.....	2
1.2	Prevent malfunction.....	3
1.3	Maintenance and Support.....	3
2	Preface.....	4
3	Introduction.....	5
4	Module introduction.....	6
4.1	Main camera.....	6
4.2	Optional lenses.....	6
4.3	Control box.....	6
5	Structure and Function.....	7
5.1	Main structure.....	7
5.1.1	Detector type.....	7
5.1.2	Housing.....	7
5.1.3	Power system.....	8
5.1.4	Video out.....	8
5.1.5	Control box.....	9
5.1.6	Combination control port.....	10
5.2	Function parameters.....	10
5.2.1	Structure and Appearance.....	10
5.2.2	Video format.....	10
5.2.3	Communication.....	11
5.2.4	Image quality.....	11
5.2.5	Consumption and Startup time.....	11
6	Menu option.....	12
6.1	Menu interface.....	12
6.2	Temp measurement menu.....	14
6.3	Non-temp measurement menu.....	16
7	Installation.....	18
7.1	Requirements for installer.....	18
7.2	Tool.....	18
7.3	Start installation.....	18
7.3.1	Main camera.....	18
7.3.2	Lens installation.....	19
8	Operating environment.....	20
8.1	Storage temperature.....	20
8.2	Operating temperature.....	20
8.3	Working humidity.....	20
8.4	Encapsulation standard.....	20
9	Manufacturer Details.....	21
10	Specifications.....	<u>22</u>

---

# 1 Reading this first

## 1.1 Safety precautions

### 1.1.1 Warning

- 1、 Before using the camera, please ensure that you read and understand the safety precautions described below. Always ensure that the IR camera operate correctly.
- 2、 The safety precautions noted on the following pages are intended to instruct you in the safe and correct operation of the IR camera and its accessories to prevent injuries or damage to yourself, other persons and equipment.
- 3、 Use only the recommended power accessories. Use of power sources not expressly recommended for this IR camera may lead to overheating, distortion of the IR camera, fire, electrical shock or other hazards.
- 4、 Do not attempt to disassemble or alter any part of the equipment that is not expressly described this guide
- 5、 The power matched with IR camera should satisfy manual criterion. Please contact our agent or us if you are not sure about the installing power.
- 6、 Stop operating immediately if it emits smoke or noxious fumes .Failure to do so may result in fire or electrical shock. Immediately turn the IR camera's power off, remove the IR camera battery or unplug the power cord from the power outlet. Confirm that smoke and fume emissions have ceased.
- 7、 Stop operating immediately if it dropped or the casing damaged.

Failure to do so may result in fire or electrical shock. Immediately turn the IR camera's power off, remove the IR camera battery or unplug the power cord from the power outlet.

- 8、 Do not use substances containing alcohol, benzene, thinners or other flammable substances to clean or main the IR camera. The use of these substances may lead to fire.
- 9、 Do not handle the power cord if your hands are wet Handling it with wet hands may lead to electrical shock. When unplugging the cord, ensure that you hold the solid portion of the plug. Pulling on the flexible portion of the cord may damage or expose the wire and insulation, creating the potential for fires and electrical shocks.
- 10、 Do not install camera to the unstable wall and support arm, or it could lead to injury of people and camera.
- 11、 Please contact us immediately if you meet situations as follows:
  - a. The power or control line damaged.
  - b. Using the wrong voltage and type of power.
  - c. Cause damage when dropping the camera.
  - d. The camera occurs functional problems.
  - e. The camera still working wrong after operating properly as user manual.

<p><b>Warning:</b> Do not aim the IR camera directly into the sun or at other intense heat source, which could damage the detector of the IR camera.</p>
--

### 1. 1. 2 Caution

- 1、 Please avoid strong vibration, heavy pressure and soaking. Or it would damage the camera.
- 2、 If you want to change the location of the installed camera, please make sure turn off the power before start.
- 3、 Please install camera in a well-ventilated circumstance.
- 4、 If the camera work abnormally, please contact us, do not disassemble or alter camera in any ways. Manufacturer has no responsibility for

- the problem that caused by the unauthorized alter or maintain.
- 5、 When installing in outside, please take effective actions to prevent camera from water, humidity and dust.

## 1. 2 Prevent malfunction

Avoid damaging the detector of the IR camera, please read contents carefully as follows:

### 1、 **Avoid Condensation Related Problems**

Moving the IR camera rapidly between hot and cold temperatures may cause condensation (water droplets) on its external and internal surfaces.

You can avoid this by placing the IR camera in the plastic case (bundle) and letting it adjust to temperature changes slowly before removing it from the case.

### 2、 **If Condensation Forms Inside the IR Camera**

Stop using the camera immediately if you detect condensation. Continue to use may damage the IR camera. Wait until moisture evaporates completely before resuming use.

### 3、 **Storage For a Long Time**

Please put the camera into a shady and dry condition when without operating for a long time.

## 1. 3 Maintenance and Support

For more maintenance and other after-sale service, please refer to the random guarantee card.

---

## 2 Preface

Thermal imaging detection technology has been imperative means to guarantee the safety of industrial production in developed countries. It is used mainly in many fields such as electrical system, metallurgy, petrochemical industry, machinery, coal, transportation, firefight, security, etc. During continuous production task in company, we can apply thermal imaging detection technology to detect device located in danger so that avoid stopping procedure of manufacturing and design. Comparing with the traditional detection method, it is no doubt that the technology has turned a new leaf in the history of detection industries.

Thermal imaging technology used widely in all kinds of industries as follows:

- Detection of electric devices and power transmission line
- Detection of hidden fire in fire fight work
- Rescue and command in fire spot
- Heat leakage and heat analysis of heat channel or heat insulation.
- Heat malfunction locating in an operating train.
- Heat analysis in electronic industry.
- Security surveillance at night in security department.

---

## 3 Introduction

SATIR Universal Purpose Core (UPC) is an uncooled long wave thermal imager core which is highly modular design for thermal product OEMs or integration with their existing products/systems. With the multiple optional solutions, image processing and the standard video output, UPC can be easily integrated in the existing surveillance & security cameras or CCTV systems, robots, UAVs and vehicles.

SATIR UPC is composed of three parts: the main camera, control box and optional lenses. It provides high-quality infrared thermal image signal, analog video output and selectable lens matched with different field of view. It is also simple to installing and operating.



---

# 4 Module introduction

## 4. 1、 Main camera

It turns the thermal radiation into visual infrared images, and realizes relevant function. Its internal structure is consisted of UFPA detector and processing main board. The system is designed with a housing which meets IP40 (optional to IP54) encapsulation standards.

## 4. 2、 Optional lenses

It collects radiation coming from target and focuses that on the detector. According to different field of view, lenses can be classified as two types: telephoto lens and wide-angle lens. The former can focus long distance and has a narrow FOV, while the later has a wide FOV but only focus shorter.

## 4. 3、 Control box

The control box is the connection between UPC and external device. Its function is to divide multifunctional port of UPC into each single output: power input, video output, COM port (RS232), meanwhile it also can control the menu settings in UPC.

---

# 5 Structure and Function

## 5.1 Main structure

Inside: detector, Main board, other component,  
Outside: housing, Connection port, control box.

### 5.1.1 Detector type

UFPA, uncooled microbolometer, Spectral range: 8~14um,  
resolution 160\*120, 25um, NETD:80mk@30°C  
resolution 384\*288, 25um, NETD:50mk@30°C  
resolution 640\*480, 17um, NETD:60mk@30°C

### 5.1.2 Housing

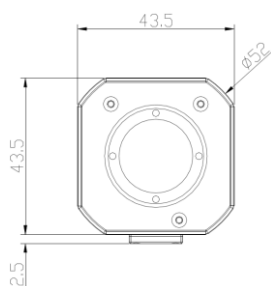

Front view

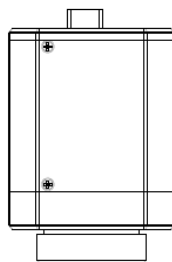

Vertical view

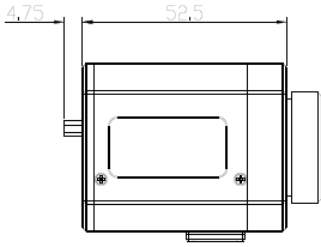

Side view

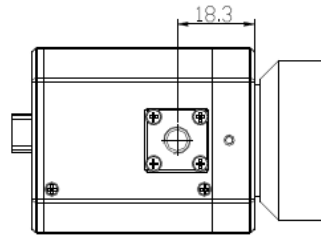

Button view

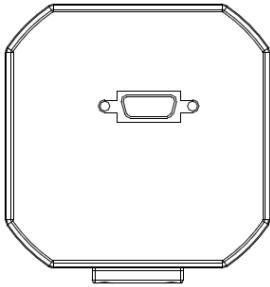

Back-end view

Connector:  
Multifunctional port

### 5. 1. 3 Power system

DC 8-12V

### 5. 1. 4 Video out

Analog video output

## 5. 1. 5 Control box

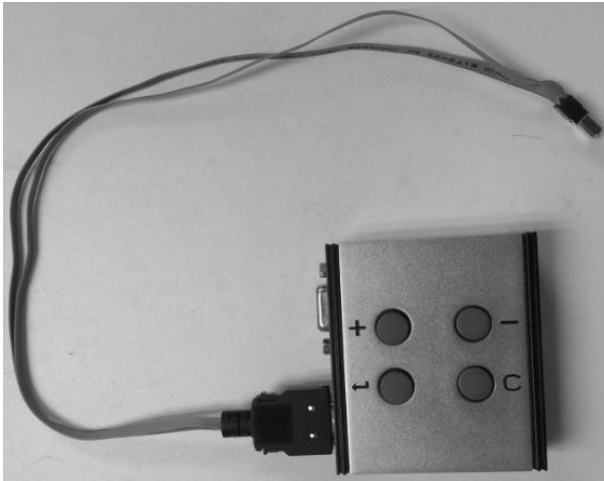

### Keypad definition:

1. Enter: pop out the menu, and save modified settings.
2. C/A: If no menu, click it to calibrate camera; if under menu, go back to previous menu level without saving.
3. Down: moving menu items/value down.
4. Right: moving menu items/value right.
5. Enter + C/A: turn the Down/Right definition to Up/Left.
6. After modified all settings, go to the version menu, and click Enter key to save all settings in UPC that will keep all settings after reboot UPC.
7. After setting Center/tracking spot, click Enter the save setting, and the click Enter again to pop out the spot.

## 5. 1. 6 Combination control port

RS232, transfer and control commands

Interface	
Port	RS232
Baud rate	9600bps
Start bit	1bit
Date bit(hex)	8 bit
Stop bit	1 bit
Parity bit	N/A

Manual control commands:

On	FF 01 00 03 00 5F 63
Off	FF 01 00 03 00 5E 62
Up	FF 01 00 08 00 04 0D
Down	FF 01 00 10 00 04 15
Left	FF 01 00 04 00 04 09
Right	FF 01 00 02 00 04 07
Enter	FF 01 02 00 00 00 03
Esc	FF 01 04 00 00 00 05

## 5. 2 Function parameters

### 5. 2. 1 Structure and Appearance

Each module should install stable and has no loose movement. The surface of housing should be clean and bright without scratches.

### 5. 2. 2 Video format

PAL or NTSC video

### 5. 2. 3 Communication

Control signal transmission

### 5. 2. 4 Image quality

The image should not involve abnormal phenomenon as follows:

Image shadows, Horizontal stripe interruption, Oblique stripe interruption, Dispersive focusing, etc.

### 5. 2. 5 Consumption and Startup time

Under normal condition:  $\leq 3W$     Startup time:  $\leq 5s$

---

# 6 Menu option

As a new generation of infrared core product, SATIR UPC possesses kinds of pseudo-color modes on the base of temperature measuring function, and contains many characteristics of temperature measuring and surveillance & security products. It has two types of menu option: temperature measurement menu; Non-temperature measurement menu.

## 6.1 Menu interface

- Temp-measurement menu interface:

Max/Min temp tracking spot: Tracking the max/min temp spot on full screen and showing a cross cursor on the spot as a marker. The value of max/min temperature present in the top right corner of screen. It allows only one max/min temperature tracking spot;

Center spot: Measuring the temperature of center spot on entire screen and showing a cross cursor on it. The value of max/min temperature present in the top right corner of screen. It allows no more than one center spot;

Isotherm: Realizing the isotherm analysis on full screen, it contains three factors: the high temperature, low temperature and isotherm width. Users can use some color (Green/Red/Black/White) to indicate a temperature range that belongs to the setting width from the low temp to high temp. It allows no more than one isotherm analysis;

As shown in below picture:

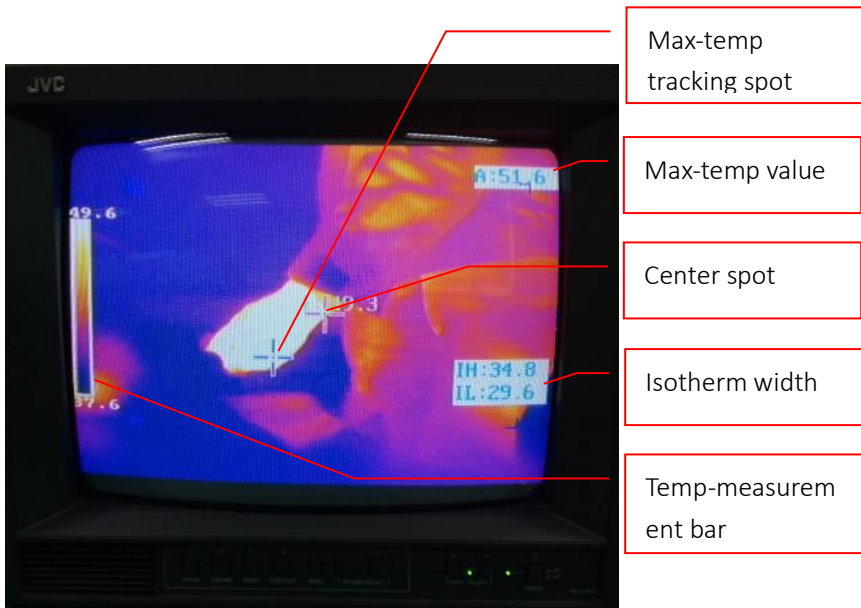

Menu model as shown in below picture (other menu options are similar to this model, more details presented in following menu excels):



- Non-temp measurement menu interface  
It just contains image ongly, not includes analysis functions of temp-measurement menu. As shown in follows (menu model are similar



to temp-measurement menu):



## 6. 2 Temp measurement menu

Analysis option:

Analysis	Image	Setup	System information
Center Spot	Off	On/Off	
Tracking Spot	Off	Max/Min/Off	
Isotherm	Off	On/Off	
Emissivity	1	0.01~1	
Distance	1 m	1~500m	
Ambient Temperature	25°C	- 60 ~ 5000°C	
Humidity	50%	0 ~ 100%	
Reflect Temperature	25°C	- 60 ~ 5000°C	
Illustration:	Default	Contents	

Image option:

Analysis	Image	Setup	System information
Palette	Iron	Iron/Rainbow/Feather/White hot/Black hot/Iron Inverted	
AGC	Level and Span	Level and Span/ Level/ Span/Off	
Continuous AGC	Off	Off/Level and Span/ Level	
Shutter Period	Normal	Off/Short/Normal	
DDE	0	0~15	
Level	25.2 °C	-40°C ~ 270°C/180°C ~ 620°C	
Span	8.0 °C	1°C ~ 270°C/4°C ~ 400°C	
Range	-20°C~+250°C	-20°C~+250°C/+200°C~+600°C	
Zoom	x1	x1/2/4	
Illustration:	Default	Contents	

Setup option:

Analysis	Image	Setup	System information
Language	English	Chinese/English	
Video Output	PAL	PAL/NTSC	
Temperature Unit	°C	°C/°F	
Distance Unit	Meter	Meter/Feet	
Alert	Off	On/Off	
Alert Temperature	30°C	30°C	
Correct Temperature	0°C	0°C	
Isotherm Width	5°C	5°C	
Isotherm Color	Green	Green/Red/Black/White	
Illustration:	Default	Contents	

System information:

Analysis	Image	Setup	System information
Serial Number	UPC XXXXXX		
Produced On	YYYY.MM.DD	2015.06.01	
Version	1.0.0	1.0.0	

### 6.3 Non-temp measurement menu

Image option:

Image	Setup	System information
Palette	Iron	Iron/Rainbow/Feather/White hot/Black hot/Iron Inverted
AGC	Brightness and Contrast	Brightness and Contrast/ Brightness/ Contrast/Off
Continuous AGC	Off	Off/Brightness and Contrast/ Brightness
Shutter Period	Normal	Off/Short/Normal
DDE	0	0~15
Brightness	6	0~15
Contrast	5	0~15
Zoom	x1	x1/2/4
Illustration:	Default	Contents

Setup option:

Image	Setup	System information
Language	English	Chinese/English
Video Output	PAL	PAL/NTSC
Illustration:	Default	Contents

System information option:

Image	Setup	System information
Serial Number	UPC XXXXXX	
Produced On	YYYY.MM.DD	2015.06.01
Version	1.0.0	1.0.0

---

# 7 Installation

## 7.1 Requirements for installer

1. Read and understand the manual completely.
2. Possess basic knowledge and operate skills in the field of electronic layout and electronic connection.
3. Possess certification of CCTV installation and maintenance. And the installer must own relevant qualification (working aloft).
4. Installer must possess basic knowledge and skills of CCTV components.

## 7.2 Tool

Straight/cross screwdriver

## 7.3 Start installation

Two main parts: 1. Main camera, 2. Lens

### 7.3.1 Main camera

See below pictures: use universal screw to mount the camera

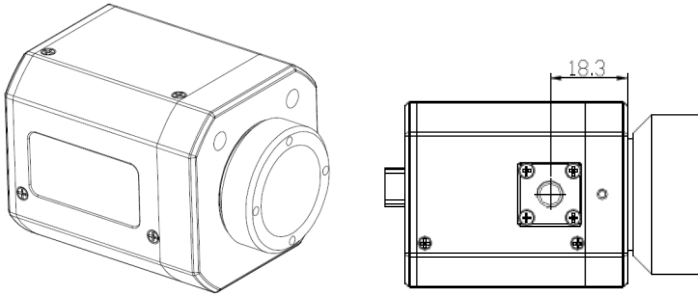

Main camera

### 7. 3. 2 Lens installation

See the below picture, point the lens direct to the camera. Plug in, and turn in clockwise direction. Focus to target, and lock the lens with the screw.

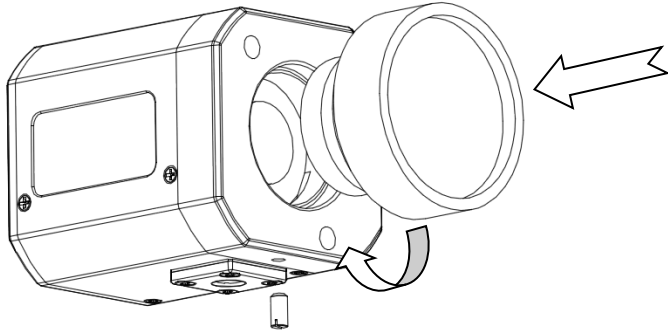

---

# 8 Operating environment

## 8.1 Storage temperature

-40°C to +70°C (-40°F to +158°F)

## 8.2 Operating temperature

-15°C to +50°C (5°F to 122°F)

## 8.3 Working humidity

≤95%, uncondensed

## 8.4 Encapsulation standard

IP40

---

## 9 Manufacturer Details

### **Manufacturer Information**

*SATIR Europe (Ireland) Co. Ltd*

*Marley's Business Park*

*Marley's Lane*

*Drogheda*

*Co. Louth*

*Ireland*

*TEL: +353 (0)41 9844371*

*URL: [www.satir.com](http://www.satir.com)*

*E-Mail: [service@satir.com](mailto:service@satir.com)*



## SATIR UPC specifications:

From 2019, UPC384 is the only available UPC Model.

UPC80, UPC160, UPC640 are pre-2019 models.

Type	UPC80	UPC160	UPC384	UPC640
<b>Imaging performance</b>				
FOV/Minimum Focus distance	51.6°x38.7° /0.3m	38.2°x28.6° /0.3m	16.3°x12.2°/0.3m	48° x36°/0.3m
Thermal Sensitivity(NET D)	100mK@30°C, #F1.0	60mK@30°C, #F1.0	50mK@30°C, #F1.0	50mK@ 30°C, #F1.0
Detector type	Focal Plane Array (FPA), uncooled microbolometer			
Resolution	80 x80	160 x 120	384 x 288	640 x 480
Spectral range	8-14um			
Focus mechanism	Fixed lens			
I.F.O.V	9.5mrad	2.4mrad	0.89mrad	1.3 mrad
<b>Measurement [3]</b>				
Temperature Range	-20°C~+250 °C (-4°F ~+ 482°F), up to 600 °C /1112°F (optional)			
Accuracy	±2°C Or ±2% Of Reading			
Measurement tools	Center spot, auto hot/cold spot, isotherm			
Temperature Alarms	Yes			
Set-up Controls	Language/ Palettes/Units			
Measurement Corrections	Ambient Temperature/ Emissivity Correction/ Distance/ Humidity			
<b>Environmental</b>				
Operating	-15°C to +50°C (5°F to+ 122°F)			
Storage	-40°C to +70°C (-40°F to +158°F)			
Humidity	95% relative humidity, non-condensing			
Encapsulation	IP40			
<b>Physical Characteristics [Camera body only]</b>				
Weight	145g			

Dimensions	43.5mm*45.5mm*52.3mm			
<b>Interfaces</b>				
Power input	DC 8-12V output to camera			
Video output	Output the composite video in NTSC@60Hz/PAL@50Hz format			
RS232	Controlling and setting			
<b>Optional Parts</b>				
Optional Lens [2]	3mm: 51.6° x38.7° Customized	6mm: 38.2° x28.6° Customized	6.8mm: 46.6°x34.9° 10mm: 30°x22° 19mm: 16°x12° 35mm: 9°x7° Customized	9mm: 73° x 53.5° 13mm: 48° x36° 25mm: 24° x 18° Customized
<b>DRI Range [Human size: 1.7m x 0.6m][1]</b>				
Detection	275m			
Recognition	70m			
Identification	46m			

Note:

[1] Data base on the 384\*288 camera with 19mm standard lens.

[2] Different lenses will cause different size and weight of whole camera.

SATIR reserves the right to change the functions and configurations of our products without prior notice.